



# MCX W71x Secure and Ultra-Low-Power MCUs for Matter, Thread, Zigbee and Bluetooth LE

## MCX-W71X

### Preproduction

This page contains information on a preproduction product. Specifications and information herein are subject to change without notice. For additional information [contact support](#) or your sales representative.

Last Updated: May 17, 2024

The MCX W71x family features a 96 MHz Arm® Cortex®-M33 core coupled with a multiprotocol radio subsystem supporting Matter, Thread, Zigbee and Bluetooth LE. The independent radio subsystem, with a dedicated core and memory, offloads the main CPU, preserving it for the primary application and allowing firmware updates to support future wireless standards. The MCX W71x also offers advanced security with an integrated EdgeLock® Secure Enclave Core Profile and will be supported by NXP's EdgeLock 2GO cloud services for credential sharing.

The MCX W71x family supports industrial and IoT devices as a single chip solution or by acting as a coprocessor in a hosted architecture. NXP delivers a complete software solution to allow the MCX W71x to operate seamlessly as a network or radio coprocessor with NXP's broad portfolio of [MCX MCUs](#), [i.MX RT crossover MCUs](#) and [i.MX applications processors](#).

Building on NXP's strong history of providing industrial edge solutions, the MCX W series offers a wide operating temperature range from -40°C to 125°C and peripherals for industrial applications, including an optional CAN interface and will be part of NXP's 15-year Product Longevity program to support long-term industrial use.

The MCX W series is supported by the [MCUXpresso Developer Experience](#) to optimize, ease and help accelerate embedded system development.

## MCX W71x Block Diagram

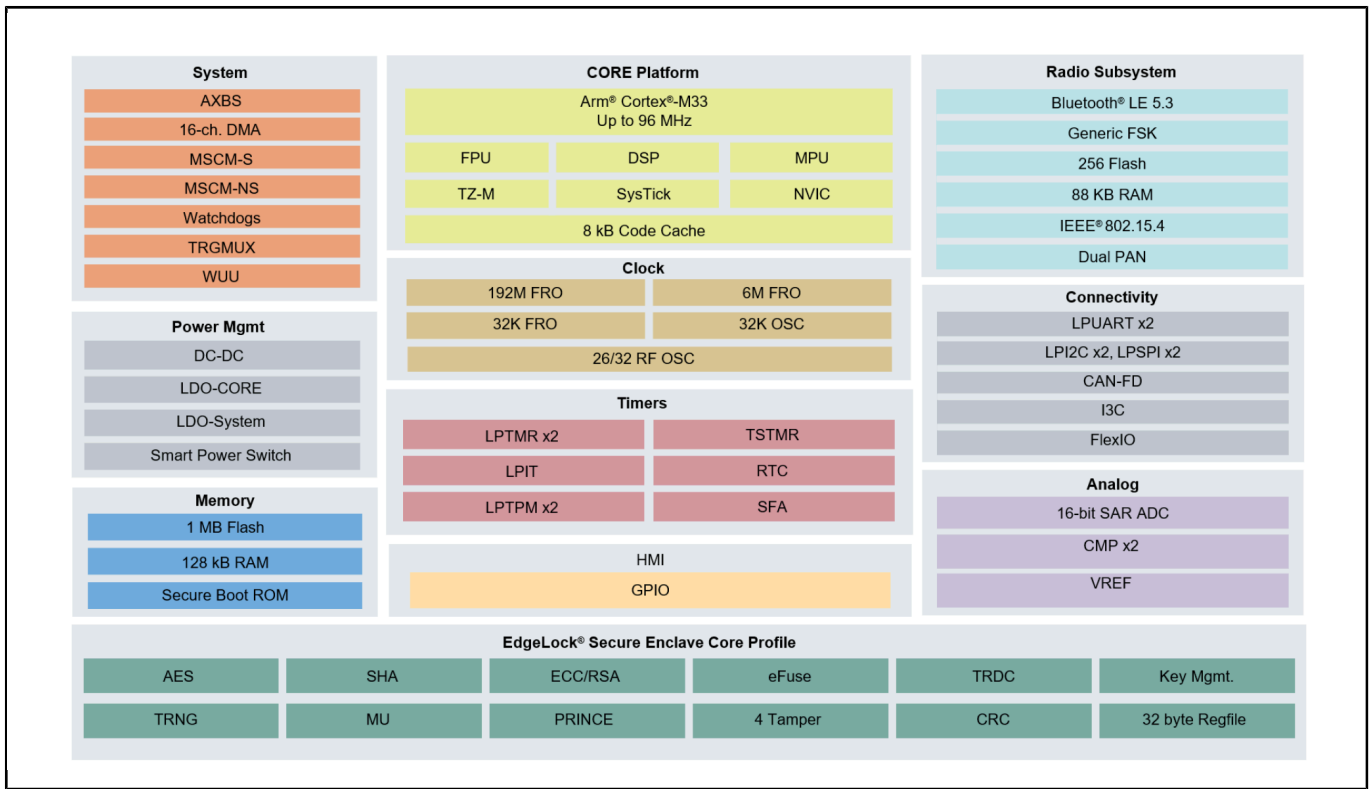

## MCX W71x Architecture Block Diagram

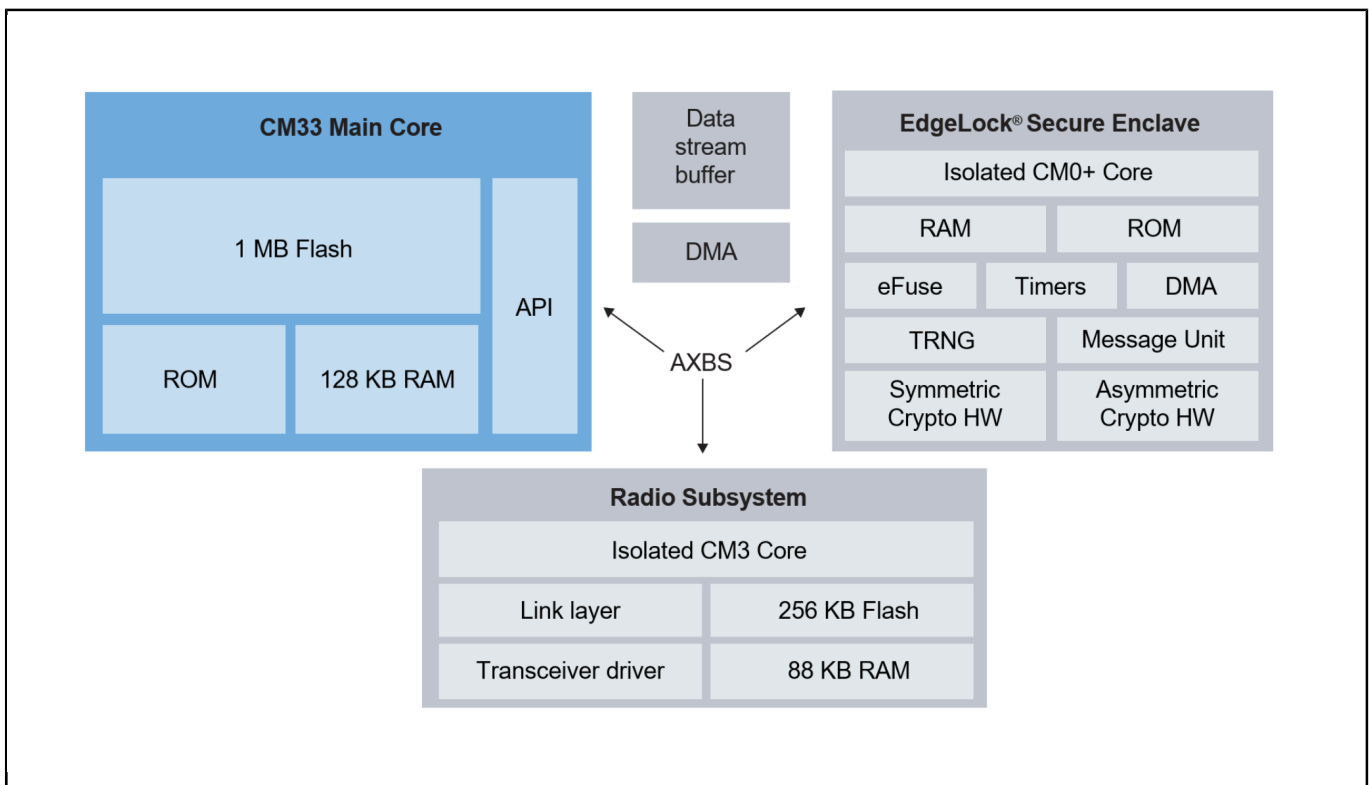

View additional information for [MCX W71x Secure and Ultra-Low-Power MCUs for Matter, Thread, Zigbee and Bluetooth LE](#).

**Note:** The information on this document is subject to change without notice.

---

**[www.nxp.com](http://www.nxp.com)**

NXP and the NXP logo are trademarks of NXP B.V. All other product or service names are the property of their respective owners. The related technology may be protected by any or all of patents, copyrights, designs and trade secrets. All rights reserved. © 2024 NXP B.V.