



16-Channel Fm+ I²C-Bus 57 MA Constant-Current LED Driver

PCA9952_PCA9955

Last Updated: Sep 5, 2022

The PCA9952 and PCA9955 are I²C-bus controlled 16-channel constant current LED driver optimized for dimming and blinking 57 mA Red/Green/Blue/Amber (RGBA) LEDs in amusement products. Each LEDn output has its own 8-bit resolution (256 steps) fixed frequency individual PWM controller that operates at 31.25 kHz with a duty cycle that is adjustable from 0 % to 99.6 % to allow the LED to be set to a specific brightness value. An additional 8-bit resolution (256 steps) group PWM controller has both a fixed frequency of 122 Hz and an adjustable frequency between 15 Hz to once every 16.8 seconds with a duty cycle that is adjustable from 0 % to 99.6 % that is used to either dim or blink all LEDs with the same value.

Each LEDn output can be off, on (no PWM control), set at its individual PWM controller value or at both individual and group PWM controller values. The PCA9952 and PCA9955 operate with a supply voltage range of 3 V to 5.5 V and the constant current sink LEDn outputs allow up to 40 V for the LED supply. The output peak current is adjustable with an 8-bit linear DAC from 225 μ A to 57 mA.

These devices have built-in open, short load and overtemperature detection circuitry. The error information from the corresponding register can be read via the I²C-bus. Additionally, a thermal shutdown feature protects the device when an internal junction temperature exceeds the limit allowed for the process.

The PCA9952 and PCA9955 devices have Fast-mode Plus (Fm+) I²C-bus interface. Fm+ devices offer higher frequency (up to 1 MHz) or more densely populated bus operation (up to 4000 pF).

The PCA9952 is identical to PCA9955 except for the following differences:

- The PCA9952 has only three hardware address pins compared to four on PCA9955
- The PCA9952 has an output enable pin (OE) and the PCA9955 does not

The active LOW output enables input pin (OE), available only on PCA9952, blinks all the LEDs outputs and can be used to externally PWM the outputs, which is useful when multiple devices need to be dimmed or blinked together without using software control.

Software programmable LED Group and three Sub Call I²C-bus addresses allow all or defined groups of PCA9952/55 devices to respond to a common I²C-bus address, allowing, for example, all red LEDs to be turned on or off at the same time or marquee chasing effect, thus minimizing I²C-bus commands. On power-up, PCA9952/55 will have a unique Sub Call address to identify it as a 16-channel LED driver. This allows mixing of devices with different channel widths. Four hardware address pins on PCA9955 allow up to 16 devices on the same bus. In the case of PCA9952, three hardware address pins allow up to 8 devices on the same bus.

The Software Reset (SWRST) function allows the controller to perform a reset of the PCA9952/55 through the I²C-bus, identical to the Power-On Reset (POR) that initializes the registers to their default state causing the output current switches to be OFF (LED off). This allows an easy and quick way to reconfigure all device registers to the same condition.

PCA9952_PCA9955 Block Diagram Block Diagram

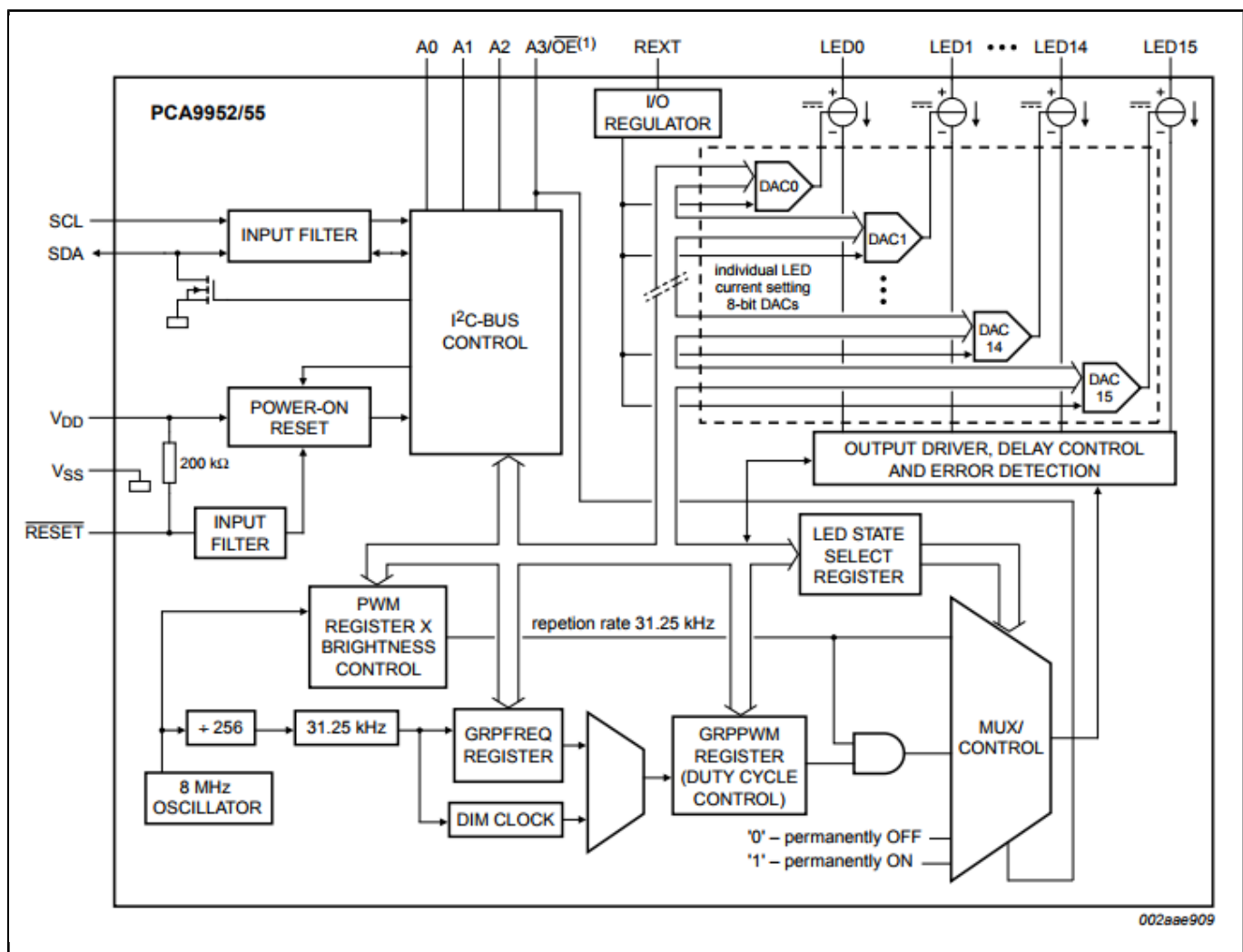

View additional information for [16-Channel Fm+ I²C-Bus 57 MA Constant-Current LED Driver](#).

Note: The information on this document is subject to change without notice.

www.nxp.com

NXP and the NXP logo are trademarks of NXP B.V. All other product or service names are the property of their respective owners. The related technology may be protected by any or all of patents, copyrights, designs and trade secrets. All rights reserved. © 2024 NXP B.V.