

Application Note

AN2066/D

Rev. 1.5, 11/2001

MPC8xx SDRAM Interface

*Heinz Wrobel**Freescale GmbH,
Munich**Janet Snyder**NCSD Applications,
Austin*

Part I Introduction

In the long term, Synchronous DRAMs (SDRAM) offer system designers at least two advantages over conventional Fast Page Mode or EDO DRAMs: a speed-upgrade and density road map to meet performance requirements of future processors, and a smooth transition to higher bus speeds without the need to implement major system re-designs. As SDRAMs reach price parity with conventional memories, SDRAM is making inroads into the PC main memory, space previously held by EDO/BEDO. This has implications for the embedded market place. Not only the performance, but also the price reductions will persuade designers to use SDRAM in preference to the previous architecture. This design concept discusses the basis of SDRAM operation, and goes on to illustrate a method of interfacing SDRAM to the MPC8xx. After describing the general procedure to interface SDRAM and the issues, a real life setup similar to the one used on the Freescale 860 FADS board is presented.

The examples generally assume a 50 Mhz version of the MPC8xx and mention the 40 Mhz Version and the 66 Mhz Version (with half speed 33 Mhz bus) if appropriate. While specific SDRAM types from various vendors are referenced in the examples, the JEDEC Standard for SDRAM (No. 21-C 3.11.5) and Intel's PC SDRAM Specification (V1.51 11/97) are also taken into account as influential documents. Based on this information, general usage of arbitrary SDRAM types should be possible.

1.1 Document Conventions

Due to the different bit numbering scheme for an SDRAM and the PowerPC architecture, address and data bits are labeled with the subscripts "SD" and "MPC" respectively. In the 32-bit definition of the PowerPC architecture, bit 0 is the most-significant bit, and bit 31 is the least significant. The standard for RAMs, ROMs, etc., is that the msb is labeled as the highest number, i.e., 31 or 15, and the lsb is labeled 0. The notation "x:y" is used in places to denote bits numbered "x" to "y" in that order. References to the User's Manual refer to the MPC860UM/AD Rev. 1. Binary numbers have a "0b" prefix. Hex values have a "0x" prefix.

Part II SDRAM Hardware Interfacing

2.1 Basics

SDRAMs contain the core of a standard DRAM. The difference is the addition of a clock-gating pin that synchronizes all inputs and outputs (address, data and control signals) to a single system clock. This makes the control interface simpler and eliminates the need to generate asynchronous $\overline{\text{RAS}}$ and $\overline{\text{CAS}}$ strobes as required by conventional DRAMs.

An SDRAM's memory array is divided into two or more banks (See Figure 1 for a Micron MT48LC2M8A1-8B SDRAM as example). This allows one bank to be precharged while the other is being accessed; a process known as interleaving. This process eliminates precharge latency, which in turn increases bandwidth. When interfacing to the MPC8xx this feature cannot be used when controlling the memories via the User Programmable Machine (UPM), as it does not support interleaving. Therefore, when using the UPM any access cycles are treated as individual cycles and the two banks are mapped sequentially in memory, i.e., bank one sits directly after bank zero in the memory map. The latter is achieved for the SDRAM used in the example by connecting A9_{MPC} to Bank Select (BS_{SD}) to act as high order address input to the SDRAM.

Each SDRAM incorporates a burst counter used to increment column addresses on each clock for burst cycles. The burst length and burst type (sequential or interleaved) is selected by programming an on-chip mode register. The length of the burst sequence may be set by the user and is programmed for 1, 2, 4, or 8 transfers within a mode register of the SDRAM. The burst sequence takes advantage of a 3 stage pipeline which allows new memory accesses to be initiated before the preceding access has been completed. When the pipeline is full, data can be accessed on every clock cycle. After a read burst is completed, the outputs are tri-stated until a new access cycle is initiated. On the MPC8xx, interleaving is not supported and the total burst length is always 16 bytes. This means that a sequential burst of four transfers should be programmed for a 32 bit bus width.

The internal SDRAM mode register settings are also used to determine when to present data-out information during a read burst. Data may be programmed to appear 1, 2, or 3 clock cycles after a read command. This feature, which is called CAS latency, allows the system designer to delay the appearance of data onto the bus until the system is ready for it. No latencies exist for subsequent cycles in a burst read cycle. Please consult appropriate SDRAM data sheets and specifications for more information about SDRAMs and especially about the specific device you are investigating. While a common CAS latency is 2, it may vary depending on the device and speed you are considering in your design.

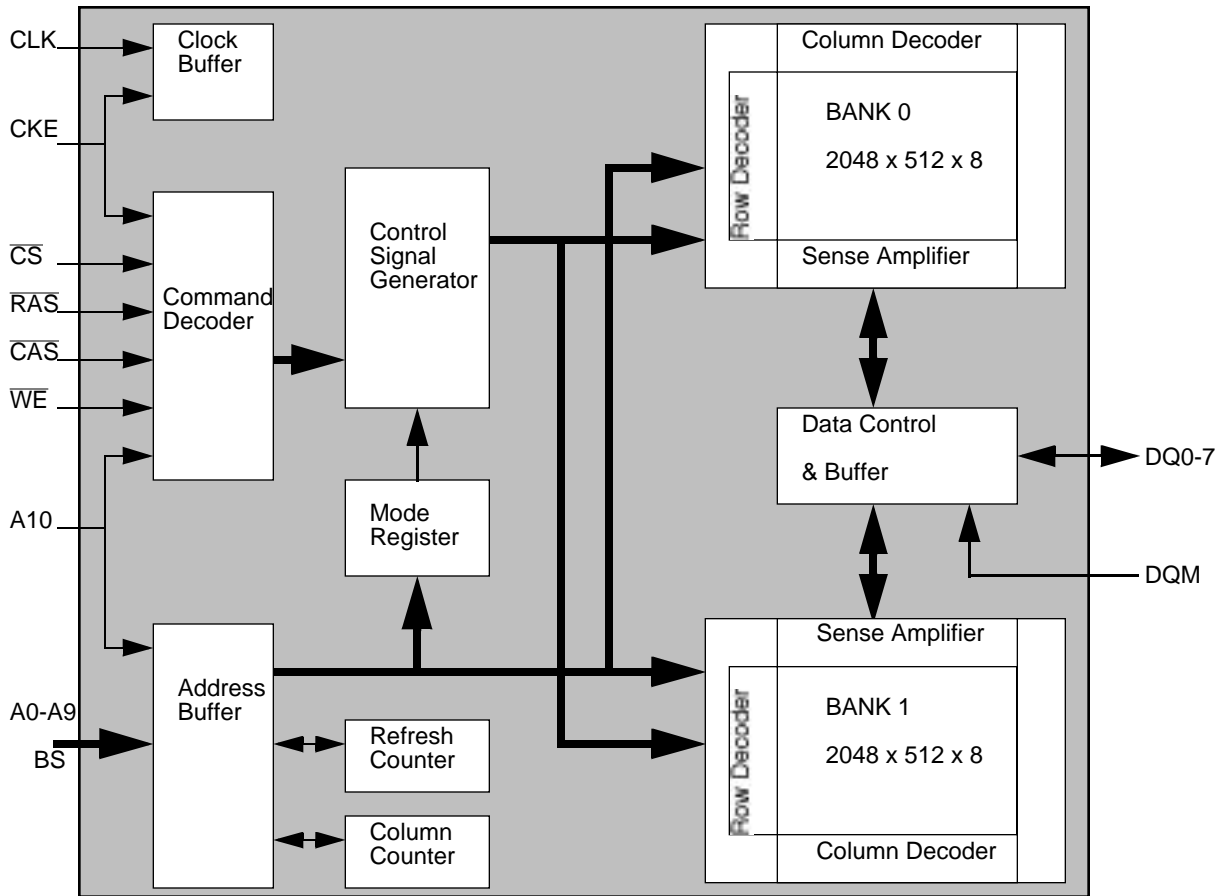

Figure 1. SDRAM Chip Architecture

2.2 Important SDRAM Timings

While SDRAM command information and data are always clocked in with the SDRAM CLK line, there are certain important timings that must be adhered to for SDRAM to function correctly. Those of special interest in this document are listed below. The example values are taken from the data sheet of a Micron MT48LC2M8A1-8B 83 Mhz device. Similar values can be found for other SDRAM devices. The values are also used to illustrate timing issues with the MPC8xx Memory Controller. Note well that t_{RCD} can also be specified in clocks with a minimum of 2 for many SDRAM devices. So intentionally a CAS latency of two clocks is used in all diagrams. The issues are mentioned appropriately. You will usually have to decide between using safe cycles that work for many SDRAM types or improved cycles that are tweaked to the timing of a specific SDRAM device in use. There is no general timing that will be best in all cases.

Timing	Micron SDRAM Value	Description
t_{RCD}	20 ns	ACTIVE to READ or WRITE delay
t_{RP}	24 ns	PRCG command period

Table 1. SDRAM Timings

Timing	Micron SDRAM Value	Description
t_{RC}	80 ns	Minimum refresh interval
t_{CAS}	2 clocks	CAS latency. Depends on CLK frequency
t_{SETUP}	2 ns	Common name for worst case signal setup times to rising edge of CLK
t_{RSC}	2 clocks	Mode Register Set Cycle Time

Table 1. SDRAM Timings

2.3 Hardware Interface

The suggested interface between an MPC8xx and an SDRAM is illustrated in Figure 2. It is clear that this is a glueless interface. For a 32 bit bus, four eight bit SDRAM devices are connected in parallel. The control is driven by the UPM on the MPC8xx, so the \overline{CS} on the SDRAM is interfaced to $\overline{CS1}$ on the MPC8xx. Any other chip select line excluding $\overline{CS0}$ would do. The DQM signals of the used SDRAM devices select byte lanes and are connected to the appropriate Byte Strobe ($\overline{BS0:3}$) signals on the MPC8xx. $A10_{SD}$ is connected to $\overline{GPL0}$, since this has the functionality to either drive an address on the line, or a defined level. This is required as $A10_{SD}$ acts as both an address line and a control line. \overline{RAS} and \overline{CAS} are generated by $\overline{GPL1}$ and $\overline{GPL2}$ respectively. The \overline{WE} is generated by $\overline{GPL3}$. CLK is driven by the MPC8xx's CLKOUT signal which is a reference point with respect to the MPC8xx's Memory Controller.

As the SDRAM used in the example has 2048 rows and 512 columns, we have to use 11 row address lines and 9 column address lines. The BS line is connected to line $A9_{MPC}$ and is used as high order address bit. Please remember that the MPC8xx address lines have a different numbering scheme than the SDRAM address lines when reading the address line mapping for 32 bit in Table 2.

MPC8xx	SDRAM
$A9_{MPC}$	BS (Most significant address bit)
$A10:20_{MPC}$	11 bits to cover 2048 rows
$A21:29_{MPC}$	9 bits to cover 512 columns

Table 2. SDRAM Address Mapping

Via the UPM Register $AMx = 0b001$, the address bits $A10:20_{MPC}$ are mapped to lines $A19:29_{MPC}$ as row addresses. As we start with line $A20_{MPC}$ to connect to $A9_{SD}$, we need to provide the left over row address $A10_{SD}$ not by using line $A19_{MPC}$ (which would show $A10_{MPC}$ as multiplexed row address), but by using $\overline{GPL0}$ as described above. In the UPM Register $MxMR$, we program $\overline{GPL0}$ to show $A10_{MPC}$ to complete row addressing.

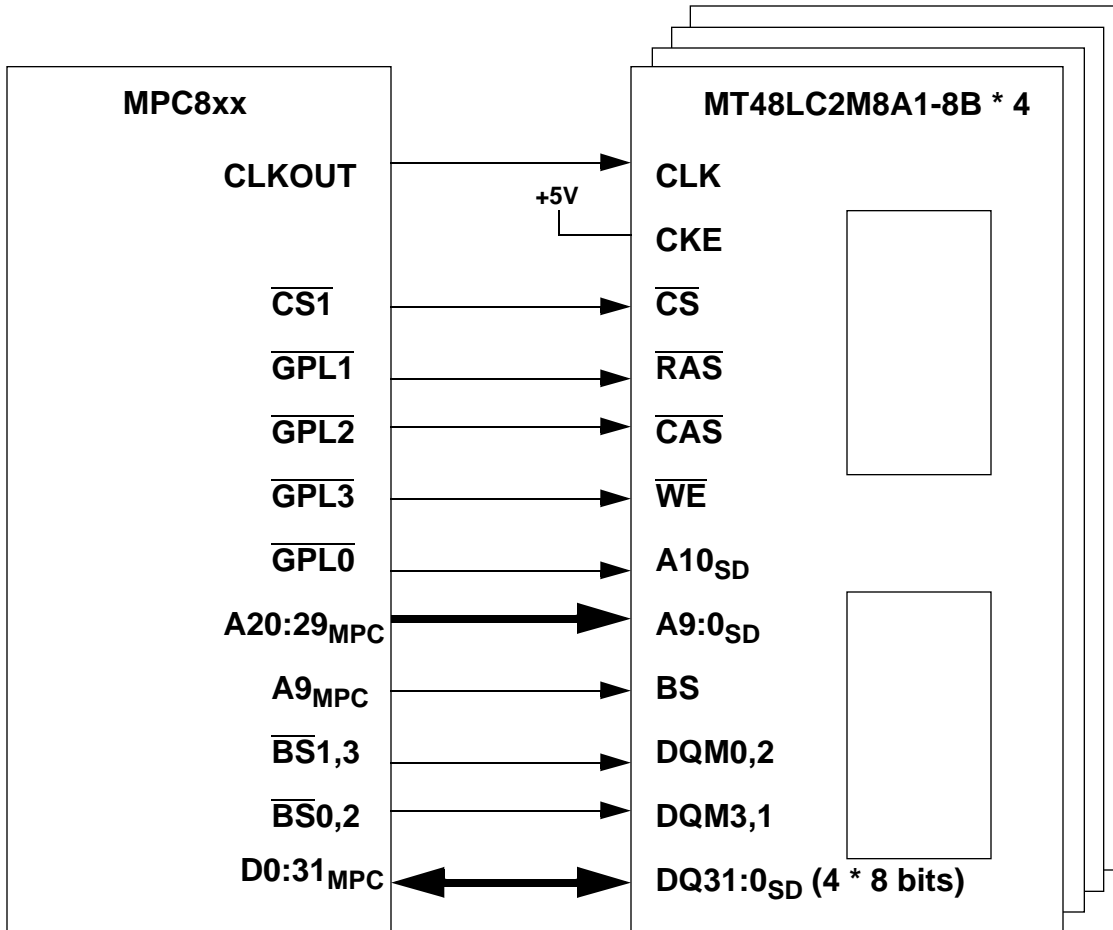

Figure 2. SDRAM to MPC8xx Interface

2.4 Multiple SDRAM Banks

Sometimes, a single 32 bit SDRAM bank is not enough memory for an application. Connecting multiple 32 bit SDRAM based banks to the MPC8xx is fairly straightforward.

If the used SDRAM chips support multiple bank select lines, extending the interface described above is easy. Above, the most significant row address bit is connected to BS_{SD}. A9_{MPC} is used due to the address size of 20 bits (9/11 address multiplex!) covered by the example SDRAM device. For an SDRAM device with two BS lines, BS0_{SD} and BS1_{SD}, you would simply use the next address bit, e.g., A8_{MPC}, with more significance to keep the memory mapping linear. In essence, you use address lines for the binary encoding of the bank selection.

If you have two physical sets or banks of 32 bit SDRAM, you would connect them in parallel but use a chip select line each. These chip select lines can then be mapped to the same UPM. Please note that you have to adapt the refresh counter settings for the UPM appropriately. The UPM references all connected chip selects sequentially. So if you use, e.g., two CS lines for two banks rather than one for a single bank on a single UPM, you have to double the frequency for the UPM Periodic Timer to keep refresh intervals for the individual CS line the same.

Part III SDRAM Usage

3.1 SDRAM Commands

The SDRAM commands used with MPC8xx are summarized in Table 3. They have the following meaning and restrictions:

ACTIV: Bank Activate Command. Row addresses are latched on A0_{SD} to A10_{SD}. A further command may not be issued until t_{RCD} has been met.

PRCG: Precharge All Command. Precharges both banks simultaneously, and then switches to the idle state. A further command may not be issued until t_{RP} has been met.

WRITE: Write Command. The write command performs a write access to the bank selected by BS_{SD} (Bank Select). The data is latched on the positive edge of CLK. The burst length and the addressing mode are programmed in the Mode Register at power-up prior to the write operation.

Command	A0-9 _{SD}	A10 _S D	CS	RAS	CAS	WE
ACTV	V	V	L	L	H	H
PRCG	X	H	L	L	H	L
WRITE	V	L	L	H	L	L
WRITEA	V	H	L	H	L	L
READ	V	L	L	H	L	H
READA	V	H	L	H	L	H
MRS	V	V	L	L	L	L
NOP	X	X	L	H	H	H
REF	X	X	L	L	L	H

Table 3. SDRAM Command Structure

WRITEA: Write with Autoprecharge Command. Performs a write command with a precharge operation automatically after the write operation. This command cannot be interrupted by any other command. A further command may not be issued until t_{RP} has been met.

READ: Read Command. The read command performs a read access to the bank selected by BS (Bank Select). The data is issued on the positive edge of CLK, at a time defined by t_{CAS}, the $\overline{\text{CAS}}$ latency.

READA: Read with Autoprecharge Command. Performs a read command with a precharge operation automatically after the write operation. This command cannot be interrupted by any other command. A further command may not be issued until t_{RP} has been met.

MRS: Mode Register Set Command. The MRS command programs the $\overline{\text{CAS}}$ latency, addressing mode, and burst length in the mode register. This must be configured after power-up as after reset the Mode Register is undefined. A further command can not be issued until t_{RSC} is met.

NOP: No-Operation. The No-Operation command simply performs no operation (the same as Device Deselect).

REF: Autorefresh Command. The autorefresh command is used to refresh the row address provided by the internal refresh counter. This is equivalent to a CAS before RAS refresh on a conventional DRAM. A further command can not be issued until t_{RC} is met.

3.2 SDRAM Access Cycles

Below, the different access cycles will be described in detail with timings. Wait clocks can be implemented as NOP clocks or device deselect clocks. Note that for most cycles an extra timing is suggested for 50 Mhz bus speed. This is sometimes needed. The reasoning for this will be described in section IV.

3.3 Initialization

The first task with SDRAM is to program the power-up sequence. The JEDEC standard for power-up is the following:

- 1) maintain NOP inputs for 200 μs - they may be maintained after power-up by driving an inactive state on the memory controller signals.
- 2) Issue Precharge command to both banks (PRCG), and wait t_{RP} , the precharge time. For $t_{\text{RP}}=24$ ns, one wait clock (NOP) is required for 50 Mhz bus speed.
- 3) Issue eight auto refresh commands (REF). Between refreshes, the refresh command period t_{RC} must be met. Based on a t_{RC} value of 80 ns, this requires two wait clocks for 33 Mhz, three wait clocks for 40 MHz, and four wait clocks for 50 Mhz.
- 4) Issue a mode register set (MRS) to initialize the mode register. This programs the burst length, CAS latency and write mode. After time t_{RSC} the first access can occur. For $t_{\text{RSC}} = 2$ clocks, one trailing wait clock is required.

The pattern illustrated below may be driven by the UPM via the appropriate programming. This complete start-up operation should be programmed into the UPM after start-up to configure the SDRAM correctly. The actual cycle is shown in Figure 3. Note that the refresh portion of the initialization may also be executed by simply waiting the required time after initialization for 8 refresh cycles. A loop in the UPM pattern to generate 8 refresh cycles is more efficient.

An MRS command is initiated by driving $\overline{\text{CS}}$, $\overline{\text{RAS}}$, $\overline{\text{CAS}}$ and $\overline{\text{WE}}$ low on the rising edge of the clock. At this point the address is sampled and its value written into the Mode Register. Note that the next command cannot be given to the memory until t_{RSC} has elapsed. Note that JEDEC recommends two wait clocks before the next command.

Mode Register Settings

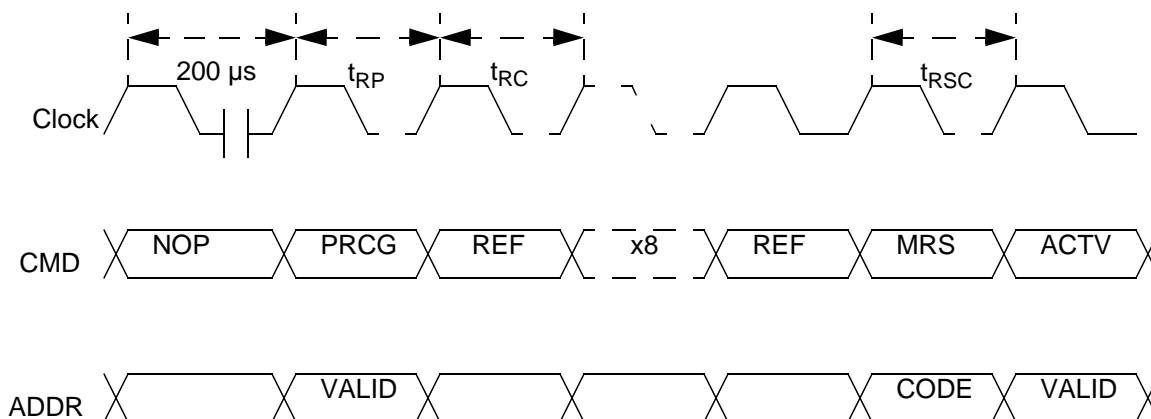

Note: Required wait clocks are not shown completely due to limited space. Observe timing specifications!

Figure 3. Power-on Initialization

3.4 Mode Register Settings

The following settings in the mode register are required:

Burst Length (A2:0_{SD}) - The burst length can be initialized to 2, 4, or 8 words. As this design is implemented using a 32-bit wide port, the burst length should be set to 4. With a 32-bit wide port, the UPM needs to do four accesses in a burst to handle the normal burst size of 16 bytes. Therefore A2:0_{SD} must be 0b010 during the Mode Register Set (MRS) command.

Address Mode Select (A3_{SD}) - This selects between Interleave mode and Sequential Mode. As the MPC860 has no support for interleaved memories, Sequential Mode is selected. This requires A3_{SD} = 0 during the MRS command. Note that the SDRAM's BS_{SD} (Bank Select) line is connected to the highest order address line from the MPC860 so that the two SDRAM banks are mapped sequentially in memory.

CAS Latency (A6:4_{SD}) - The CAS latency is the number of clocks from the Read command to data valid. Now, this depends on two factors, the system clock frequency and the speed of part used. For for a 100 MHz part interfacing to a 40 MHz or 50 Mhz bus this should be 2. A6:4_{SD} would be set to 0b010 during the MRS command. With a 33 Mhz bus, a CAS latency of 1 is ok, so 0b001 on A6:4_{SD} would be the corresponding value. Note that a CAS latency of 1 may not be supported by every SDRAM device. You may always have to use a CAS latency of 2, depending on the SDRAM device.

Write Mode (A9_{SD}) - Write mode should be configured for Burst read and Burst write, so A9_{SD} is set to 0 during the MSR command.

All remaining address bits should be set to zero. The total address value required on the SDRAM address lines is therefore, e.g., 0b100010 or 0x22 for 50 MHz. As the MPC860 is connected with a 32 bit bus, the actual value is shifted by two bits on the MPC860 address bus, resulting in a value of 0x88 to be used for a 50 MHz design.

3.5 Single Write Cycle

Each write cycle is activated with an ACTV command. The SDRAM requires a delay of t_{RCD} from the ACTV command to the next command, WRITE. The reason that a WRITE command is used instead of a WRITEA command is because the cycle is required to terminate after one access. For a clock of 50 MHz the period is 20 ns, so the next command may not be given on the next clock due to lack of any margin. A wait clock can be found in Figure 4 because of t_{RAS} with 40 MHz. The write is terminated with a PRCG command after another dummy cycle for 50 MHz. As t_{RAS} is 50 ns, we need to add wait clocks again for higher bus speeds than 33 MHz. The next ACTV command may not be driven until t_{RP} is met. As this is 24 ns, an extra cycle must be added to the end of the access for 50 MHz. This results in a complete best case access time of 3 clocks for 33 Mhz, 4 clocks for 40 MHz, and 5 clocks for 50 Mhz. The clock count for 50 Mhz takes UPM behavior as described in section IV into account for the best case value. Figure 4 shows the general approach, with a wait clock either in the front or in the back of the cycle.

The DQM signal is shown in Figure 4 once for reference purposes only. It has to be set appropriately for any type of data access cycle and will be omitted in subsequent diagrams.

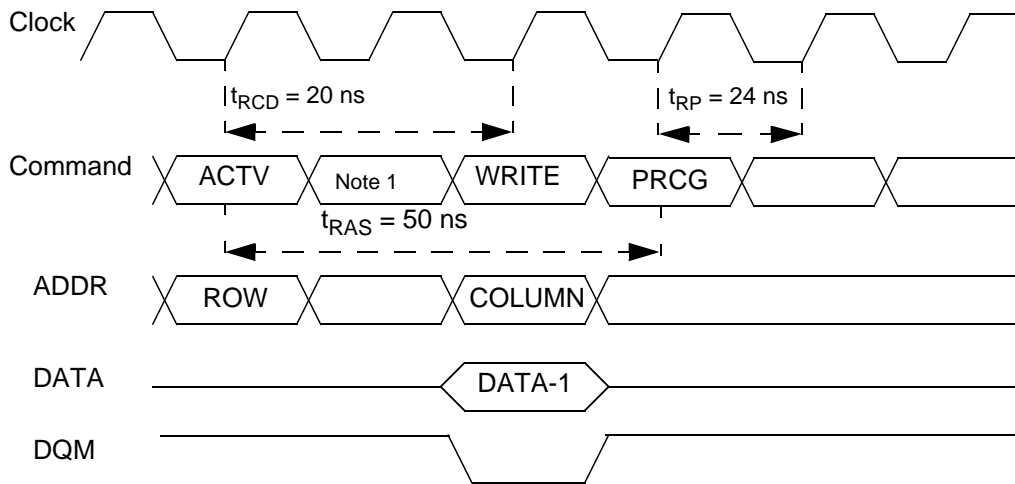

Note 1: Not really needed for this t_{RCD} , but for t_{RAS} at 40 Mhz.

Figure 4. Single Write Cycle (33 MHz and 40 Mhz)

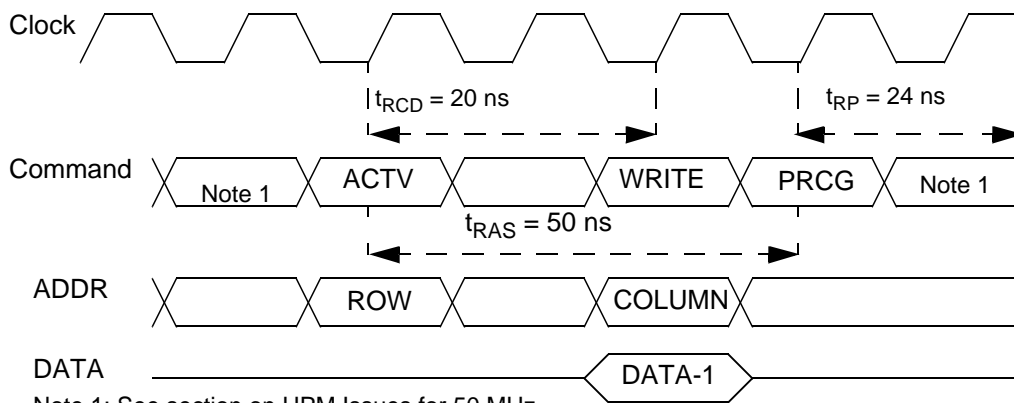

Note 1: See section on UPM Issues for 50 MHz.

Figure 5. Single Write Cycle (50 Mhz)

3.6 Single Read Cycle

Each read cycle is activated with a ACTV command. The SDRAM requires a delay of t_{RCD} from the ACTV command to the next command READ. The reason that a READ command is used instead of a READA command is because it is required to terminate the cycle after one read. The next command must wait t_{RCD} before being issued. The read is terminated with a PRCG command. The next ACTV command may not be driven until t_{RP} is met. As this is 24 ns, an extra cycle must be added into the access for 50 MHz. This results in a complete best case access time of 4 clocks for 33 MHz and 5 clocks for 40 MHz. Note that the total cycle length doesn't change when removing the wait clock after ACTV because of t_{RAS} . As shown in Figure 7, a 50 Mhz access looks fairly similar and can also have a best case access time of 5 clocks.

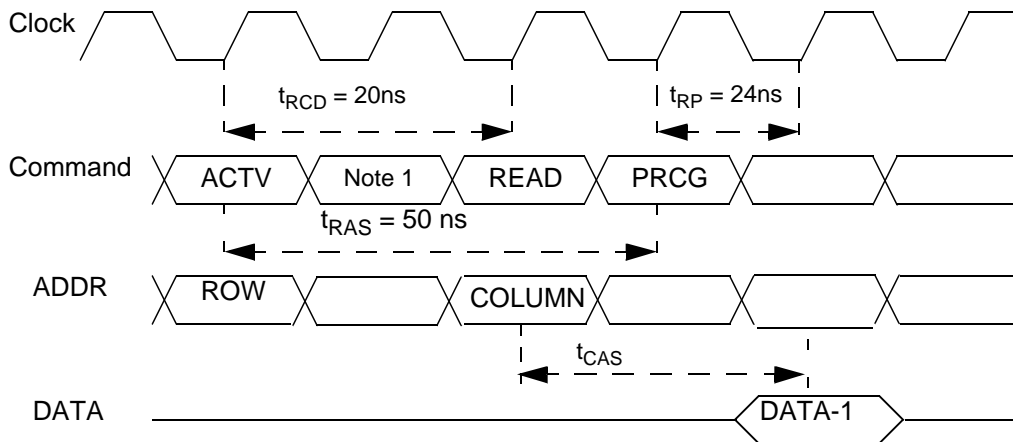

Note 1: Not really needed for this t_{RCD} , but for t_{RAS} at 40 Mhz.

Figure 6. Single Read Cycle (33 MHz and 40 MHz)

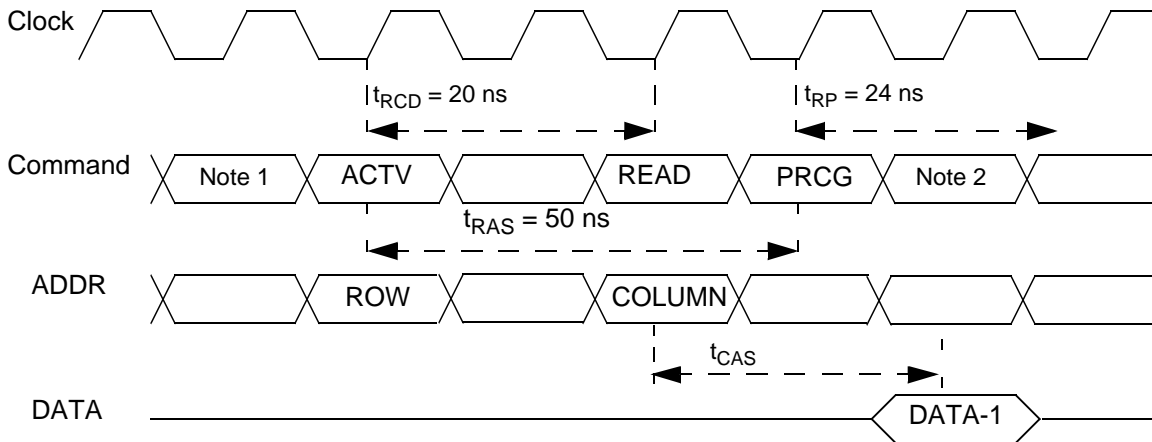

Note 1: See section on UPM Issues for 50 MHz.

Note 2: Needed, but conveniently overlaps with DATA-1. No extra clock required.

Figure 7. Single Read Cycle (50 MHz)

3.7 Burst Write Cycle

Each write cycle is activated with an ACTV command. The SDRAM requires a delay of t_{RCD} from the ACTV command to the next command WRITEA. For the burst cycle a WRITEA, write with precharge, is used. This will execute a 4 beat write, starting on the rising edge of this cycle. The data is then sampled on this and the next three rising clock edges. It will also execute a automatic precharge cycle at the end of the access. This access will be after the final data write. The next ACTV command may not be driven until t_{RP} is met. As this is 24 ns, an extra cycle must be added into the access for 50 MHz. This results in a complete best case access time of 6 clocks for a 33 Mhz or 40 MHz bus (2/1/1/1/+1). A 50 Mhz bus requires 8 clocks as can be seen in Figure 9, using a (4/1/1/1/+1) cycle.

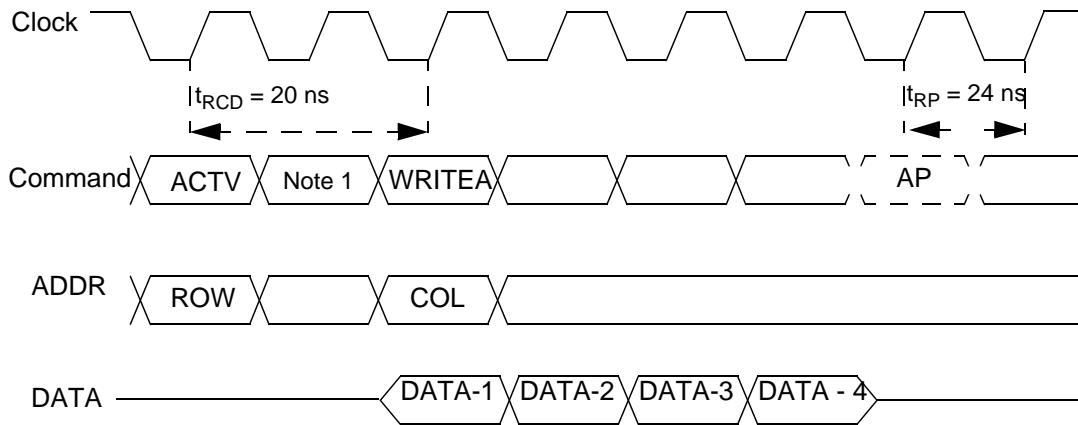

Note 1: Not really needed for this t_{RCD} . May be needed for slower devices.

Figure 8. Burst Write Cycle (33 Mhz and 40 MHz)

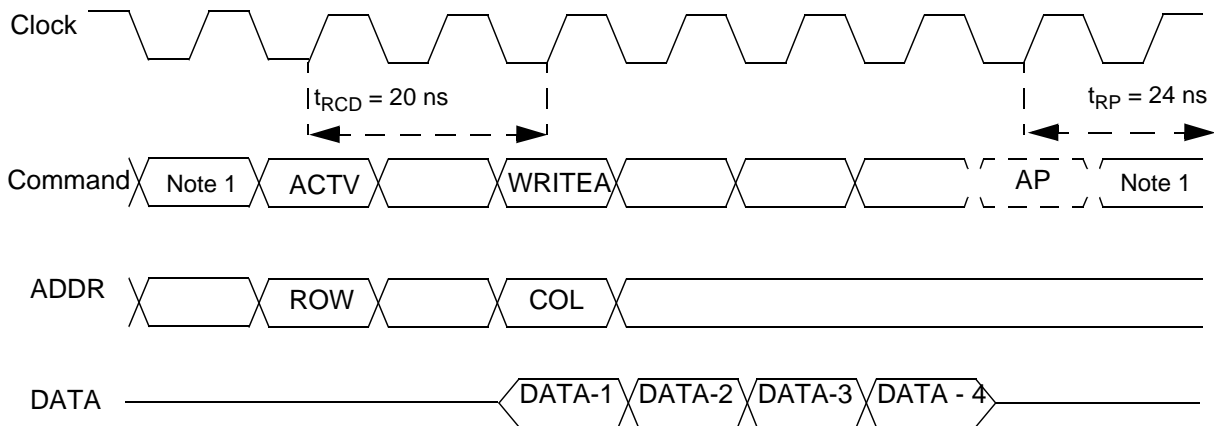

Note 1: See section on UPM Issues for 50 MHz.

Figure 9. Burst Write Cycle (50 MHz)

3.8 Burst Read Cycle

Each read cycle is activated with a ACTV command. The SDRAM requires a delay of t_{RCD} from the ACTV command to the next command READA. For the burst cycle a READA, read with precharge, is used. This will execute a four beat read, starting on the rising edge of the next cycle. The data is then presented on the next four rising clock edges. It will also execute an automatic precharge cycle at the end of the access. This access is simultaneous to the final data read. The next ACTV command may not be driven until t_{RP} is met. As this is only 24 ns, no extra cycle must be added into the access due to the overlap with the data transfer. This results in a complete best case access time of 7 clocks for a 33 MHz or 40 MHz bus (4/1/1/1). For 50 Mhz, a different timing is needed, resulting in 8 clocks best case total access time (5/1/1/1), depending on the 860 chip revision. See section IV for more information.

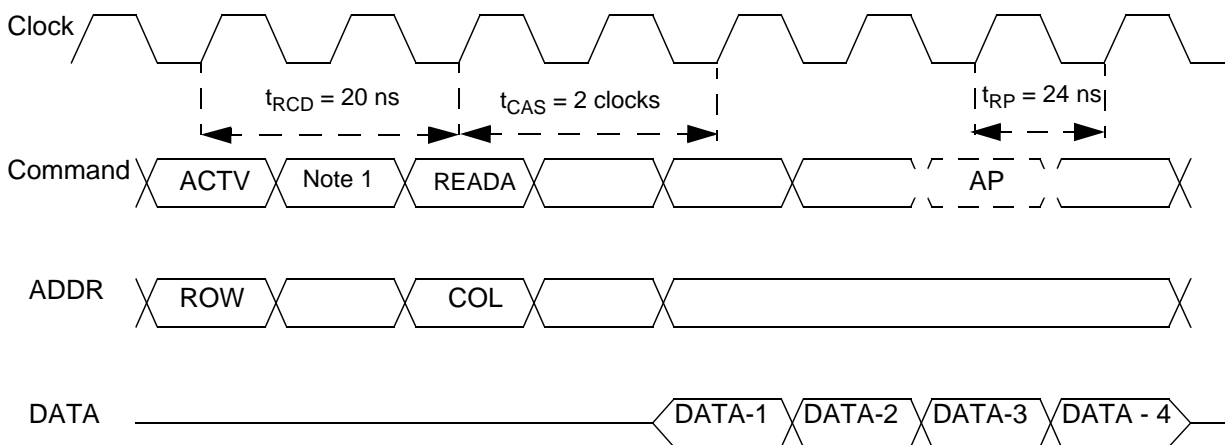

Note 1: Not really needed for this t_{RCD} . May be needed for slower devices.

Figure 10. Burst Read Cycle (33 Mhz and 40 MHz)

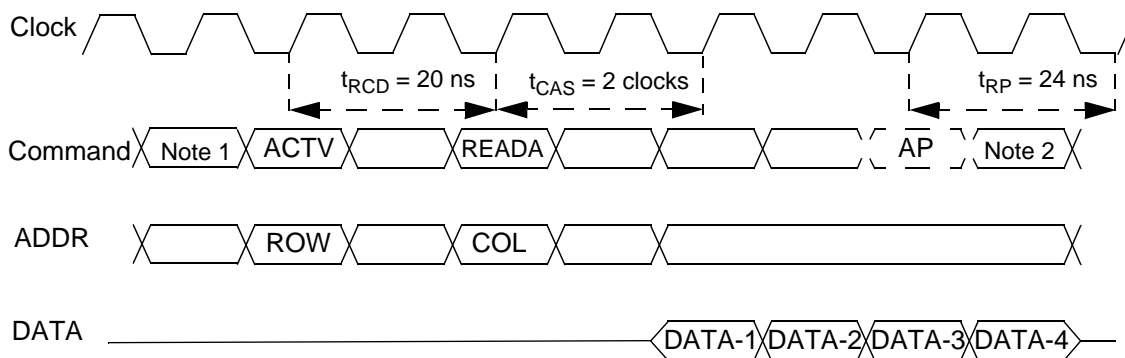

Note 1: See section on UPM Issues for 50 MHz.

Note 2: Needed, but conveniently overlaps with DATA-4. No extra clock required.

Figure 11. Burst Read Cycle (50 MHz)

3.9 Refresh Cycle

A refresh access is shown in Figure 12 for a 33 MHz and 40 MHz bus. This is initiated by the UPM's refresh counter, and executed as defined in the UPM table by a auto refresh command. Note that t_{RC} must be met. This is 80 ns. Therefore for a 33 MHz bus, 2 wait clocks are required before the next command while 40 MHz needs one additional wait clock. For a 33 Mhz you need three, for 40 MHz four, and for a 50 MHz bus five total clocks for a best case timing. Note that Figure 13 tries to illustrate the general case.

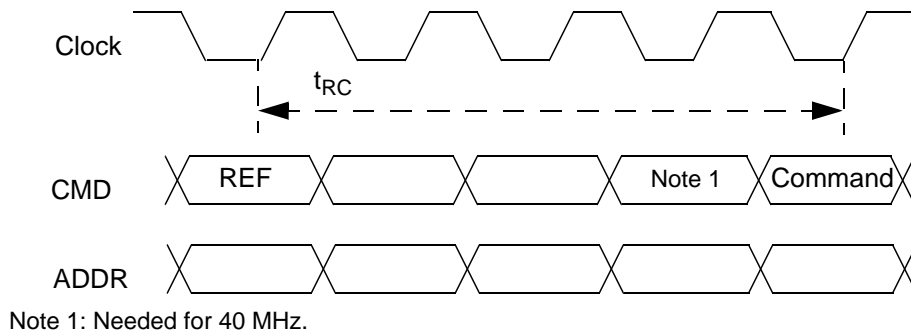

Figure 12. Refresh Cycle (33 Mhz and 40 Mhz)

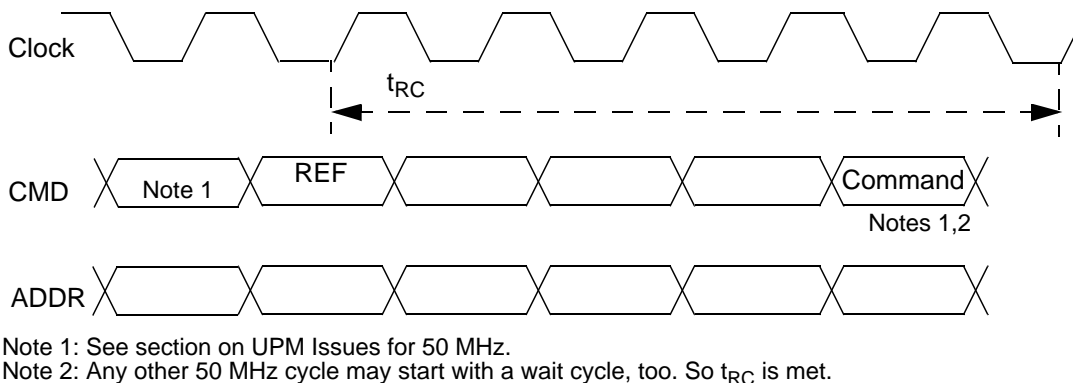

Figure 13. Refresh Cycle (50 Mhz)

3.10 Estimated Performance

Table 4 shows the estimated performance in CPU clocks when using SDRAM with an MPC8xx. Note that the bus clock is mentioned, not the CPU clock. The access times calculated include provision for precharge. Note that the better timings are listed for 50 MHz. This depends on the 860 chip revision as outlined in section IV. Also note that the implicit wait clock as outlined in section 4.1 is not included in the listed access times. Be careful when adapting these values to the real world.

CLKOUT	Single Read	Single Write	Burst Read	Burst Write	Refresh
33 MHz	4 (120 ns)	3 (90 ns)	7 (210 ns)	6 (180 ns) ¹	3 (90 ns)
40 MHz	5 (125 ns)	4 (100 ns)	7 (175 ns)	6 (150 ns) ¹	4 (100 ns)

Wait clocks and back to back cycles

CLKOUT	Single Read	Single Write	Burst Read	Burst Write	Refresh
50 MHz	5 (100 ns)	5 (100 ns) ¹	8 (160 ns)	8 (160 ns) ¹	5 (100 ns)

Table 4. SDRAM Performance

¹: These cycle times could be improved by one clock if the actual design allows to take the implicit wait clock (See section 4.1) into account for precharge purposes.

Part IV UPM Issues

This document tries to describe SDRAM interfacing for different bus speeds. This led to the different timings shown above and various possibilities for variations with respect to UPM patterns, depending on the SDRAM device used and your goals for interfacing. Leaving aside timing specifications of SDRAM, there are two basic issues, wait clocks and 50 MHz bus speed, that should be understood well, when setting up UPM RAM words.

4.1 Wait clocks and back to back cycles

Each SDRAM access needs to finish with precharged banks because of not having bank or interleaving support as explained in section 2.1. The precharge time, e.g., $t_{RP}=24$ ns needs to be taken into account before the next UPM pattern can be run, which translates into one wait clock until the next command for 50 MHz. UPM behavior helps in avoiding that wait clock in the patterns. Note that after processing the last UPM RAM word of a pattern, there is one implicit “wait” clock before the first word of the next pattern can be started. This implicit clock appears due to the setup work like early $\overline{GPL5}$ setting or SAM support via ORx registers before the first UPM word of the next pattern is run. In effect this means that UPM RAM words of two patterns never execute fully back to back. There is always at least one “inactive” clock in between when a new UPM access is started. In our application this means that we can use this implicit wait clock to take care of precharge requirements in our UPM patterns. It also means that this implicit and unavoidable wait clock will appear in our access clock count, even though it may not really be necessary for some cycles.

4.2 Using 50 Mhz Bus Speed

For bus speeds of less than 50 Mhz, the SDRAM cycles described above can be converted into UPM patterns directly.

Note: For 50 Mhz bus speed, the conversion of the timing diagrams into UPM patterns depends on the 860 chip revision that you intend to use. UPM timing specifications B3x have been improved for MPC860 Rev B.1 silicon starting at date code 9829 or later. Rev B.1 silicon with date code 9829 and newer has a maximum B3x specification of 6 ns rather than 8 ns. For the 860T, the date code is 9840 or later. This is currently **not** the case for all MPC850's where improved timings have not yet been specified.

For earlier chips without the improved timing specification, an additional trick needs to be used, resulting in the net performance described in Table 4 and the slightly different figures used to describe the cycles. All SDRAM commands are clocked in by the SDRAM with the rising edge of CLKOUT. The setup time $t_{SETUP}=2$ ns in this example has to be met. The UPM puts out timings relative to the falling edge of

CLKOUT as described in chapter 16 of the MPC860 User's Manual. The maximum time for the relevant signals in the UPM cycles is specified as 8 ns for a 50 MHz MPC8xx without the improved specification. This means that the setup time for the SDRAM signals can't be met within the 10 ns available in half a clock cycle as no margin is left for signal propagation. The result is that the actual UPM timing for each access cannot to be started in the first UPM entry (named CST4 or GxT4 in the User's Manual for the MPC860 in Figure 16-36) for any UPM cycle. The solution is to add an initial, mostly idle, dummy clock and use the last of the four UPM slots (CST3 and GxT3) within that dummy clock cycle to set up the SDRAM signals for the following rising edge of CLKOUT. The same early setup should be done for all the following clocks to meet the setup times in every clock of a UPM pattern. The UPM RAM words have to be set up appropriately.

Obviously this alone would add one full dead clock cycle to any SDRAM access. As any SDRAM access has to finish with a precharge/refresh command and at least one wait clock for a 50 MHz bus, we can shave off one wait clock at the end of some UPM cycles for the one that we have to add in the front. This way, the refresh and precharge times t_{RC} and t_{RP} will still be met, as the UPM cycles are basically "rotated" 0.75 clock cycles to the right.

For Rev B.1 silicon or better as described above the situation is easier. Here, rotating the pattern as described above is not necessary because of the 2 ns margin left with respect to $t_{SETUP}=2$ ns of the example SDRAM.

Part V Design Variations and Caveat's

5.1 Hardware Issues

Obviously, this design concept does not present the only possible way to implement an SDRAM design. The MPC860 SAMBA reference design and the FADS board introduce small variations due to the different SDRAM device type used. The address mapping is slightly different as can be seen by the use of $A10_{MPC}$ for $A11_{SD}$ (which is essentially equivalent to BS_{SD} as used in this document). It would also be permissible to shuffle around use of $\overline{GPL1}$ to $\overline{GPL3}$, as these lines are functionally interchangeable or use any chip select line except for $\overline{CS0}$.

5.2 Address and Data Line Mapping

An issue to be aware of is address and data line mapping. Historically, it has been possible to fairly arbitrarily shuffle around address or data lines to facilitate PCB layout or obfuscate designs with DRAM's or SRAMs. This is no longer easily possible for address lines on SDRAM devices. As the address lines are used to convey configuration information to the SDRAM device, care should be taken to create a normal mapping that is not arbitrarily changed during PCB layout. Note again that PowerPC bit numbering is different from SDRAM bit numbering. Take special care when mapping data and address lines.

5.3 Address Multiplexing Options

Address multiplexing tends to be a hot topic, too. This is due to the variety of available SDRAM devices and the abundance of MPC8xx options to control address multiplexing. One issue here that leads to confusion is how to make the decision if an address pin needs to be multiplexed or not. As the lower order address pins are connected to the SDRAM device, the "natural" connection is for the column address. The multiplexed address is the row address. For an SDRAM device, the row address uses typically more significant bits than the column address. This means that the high order address bits on the SDRAM device

SDRAM technology

that are not used for column addressing can be connected either via the multiplex scheme or directly. Two different methods of connecting address lines lead to identical results here. Consider, e.g., a 12/8 row/column mapping for a 32 bit bus. As in the 860 FADS schematics, A29-A18_{MPC} can be used for the address lines A0-11_{SD}. With an AMx value of 0b000, A11_{SD} (connected directly to A18_{MPC}) is multiplexed to A10_{MPC} for row addressing as expected. The same is respectively valid for the other address lines. Now consider that A8-11_{SD} are never used for column addressing here. Basically this means that you don't really have to connect these lines via the AMx mechanism, given the environment of this example. You could directly interface them to A13-10_{MPC} without any functional change. This illustrates an issue that could be considered philosophical, unless, e.g., routing issues make it practical. If AMx multiplexing needs to be used, it could on one hand be used for all address lines that it covers for consistency reasons. On the other hand, it could be argued that row addresses not in need of column multiplexing should be connected directly to avoid ambiguity issues. The 860 FADS design actually implements both schemes. A11_{SD} is connected directly to A10_{MPC}, while the remaining lines are connected based on AMx multiplexing.

5.4 SDRAM technology

SDRAM technology is evolving, too. Setup times for signals tend to get reduced, and, eventually, timing may well be tightened even more for some devices, saving clock cycles in access time. Recently ESDRAM appeared on the market. Due to internal improvements, read accesses can usually be shortened by one clock compared to normal SDRAM devices. Keeping advancements like these in mind, it is well worth investigating multiple vendors before deciding on a high performance SDRAM device that fits the application well. Also, you should consider if you set up UPM patterns specifically for a certain SDRAM device or make them general enough to work with various SDRAM timings as specified by multiple vendors.

5.5 Timing Issues

Last but not least, you should never forget timing issues. The described timings do not take any buffering into account. If you intend to use SDRAM modules requiring buffering in your design. You may have to check every single suggested timing to take buffering into account. Don't forget that buffering for address and data lines and buffering for the clock may behave differently. When deciding on buffers, don't forget to check load capacitance values for the devices used. Often it is best for system performance to connect the SDRAM unbuffered and, as appropriate, buffer the rest of the system. Clock jitter, skew, and trace delays may also affect your timing. If in doubt, start out with a safe pattern. Premature optimization is the root of all evil, Donald E. Knuth once said.

Part VI SDRAM on the MPC8xx FADS Board

This section will illustrate an actual implementation of an SDRAM interface to the MPC8xx family, including register settings and some basic UPM patterns. It steps through the system design for using two 100Mhz SDRAMs in an MPC8XX system with a bus speed of 50Mhz, utilizing the MPC8XX's Memory Controller's User Programmable Machine B (UPMB): the Hardware Interface, System Specifications, and SDRAM Initialization. This is intended as a procedural guideline only, and is not optimized for system performance. You will notice that once again different SDRAM types are shown to illustrate this example.

Note: The cycles and UPM patterns presented here rely on being used with an MPC860 of at least Rev B.1 with date code 9829 or later, except for the MPC860T where the date code is 9840 or later, see section 4.2.

6.1 The assumed SDRAM hardware

This example system, comparable to both the Freescale MPC8XX Family Application Development System (FADS) and the MPC860T SAMBA Reference Design, uses two JEDEC standard SDRAMs that are 2 x 512 x 16. Examples of these SDRAMs are the Fujitsu MB811171622A and the Samsung KM416S1020B. They are configured in this system as 2 X 512K X 32, providing a total of 4 MBytes. See Figure 14 for details.

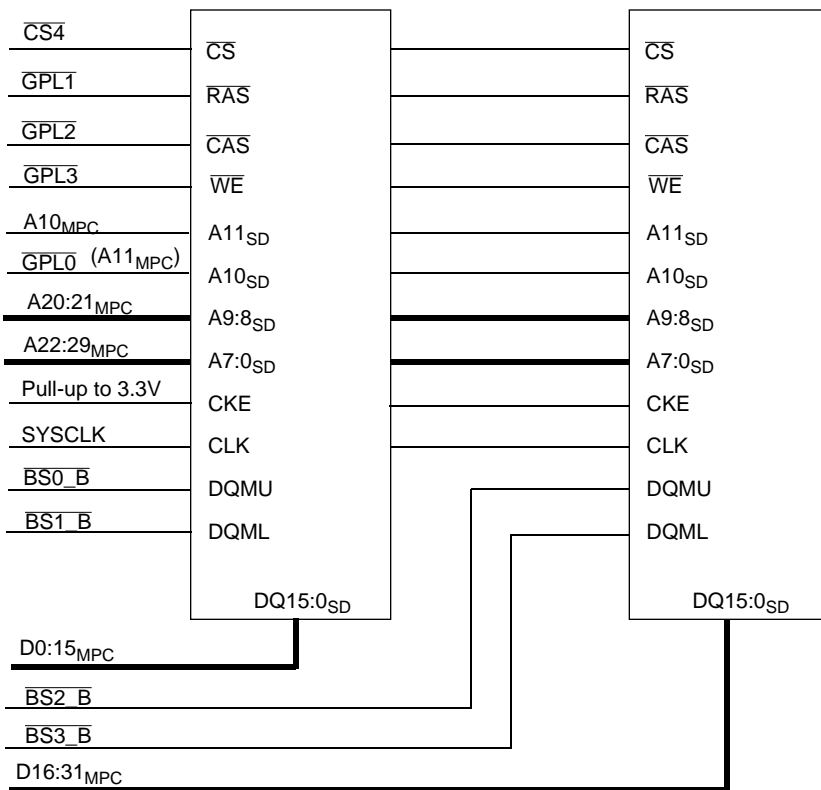

Figure 14. Example Hardware Interface

Note that in this example, the SDRAM is unbuffered from the processor, saving the delay associated with address and data buffers. This is an optimal design from the performance standpoint. Be sure to keep the loading on the address and data buses within the MPC8XX specification, which is 50 pF. For instance, this SDRAM has 4 pF on the address lines and 5 pF on the data lines, so with two of these on the buses, there are 42 pF left for the address lines and 40 pF left for the data lines to accommodate buffers and any other devices which need a raw address or data line connected.

Although this is mentioned above, it bears repeating here. Do not try and reverse the numbering of the address and data buses. It is tempting to do so for the sake of being able to think of the numbering in a MC68360 way, but with SDRAM the risk of error is greater than during a simpler paged-mode DRAM or EDO DRAM design. With SDRAMs, initialization of various parameters are done via specific address lines,

as well as control and, of course, coordination with byte lanes. We will cover this initialization and control in greater detail later. So, leaving the numbering as-is, an SDRAM's DQ0:15_{SD} correlates to the MPC8XX's D31:16_{MPC}, and the same goes for the address line scheme.

6.2 SDRAM System Specification

Before beginning programming for the MPC8XX memory controller, two system's specifications must be calculated for the SDRAM: the SDRAM performance for each cycle type and the programming needs of the SDRAM's Mode Register.

For this example, the SDRAM's performance figures for each cycle type, are shown in Table 4 on page 13. These numbers are used in both initialization and UPM RAM Array programming for designating and generating these cycle types. The values are based on the given system clock speed and the speed of the SDRAM, which in this example is 100 Mhz.

The SDRAM's Mode Register can be likewise charted for ease later in programming. These are values used during SDRAM initialization which will tailor the SDRAM for various specific system values. Here are the ones required in an MPC8XX design. Luckily, they can remain the same in our bus frequency range:

SDRAM Option	33 - 50 MHz
Burst Length	4
Burst Type	Sequential
CAS Latency	2
Write Burst Length	Burst

Table 5. SDRAM Mode Register Programming

For an explanation of these values and their mapping to the SDRAM address lines, please refer to section 3.4. Net result is an address pattern of 0b0100010 on the SDRAM address bus.

Remember that due to the 32 bit access via two SDRAM devices, the required address value will be shifted left by two bits on the MPC8xx address bus. In our example of a 50 Mhz bus with the 100 Mhz SDRAMs, the SDRAM's Mode Register value to be used by the MPC8xx will be 0x88.

6.3 The UPM Patterns

Note: NOTE: RAM Array words used in this example can be used on both the MPC8XX FADS and MPC860T SAMBA Reference Design. They are not necessarily optimal patterns. They can be used for verification purposes when implementing your own patterns based on the suggested timings above.

6.4 The Initialization Pattern

Now we need to find what waveform patterns need to be generated to the SDRAM during initialization to set it for specifically how it operates within our system. Each SDRAM spec identifies this procedure of pattern generation. It typically involves the manipulation of \overline{CS} , \overline{CAS} and \overline{RAS} , and \overline{W} lines. It also uses an address line; in our example, this is $A10_{SD}$, which corresponds to $A11_{MPC}$. For the latter, we set the General Line 0 Control A (G0CLA) bits to 0b001, which allows $A11_{MPC}$ to fall out through the $\overline{GPL0}$ pin.

The patterns needed are generated as UPM RAM Array words, created the same way as RAM Array words are created to generate a cycle type, such as a Single Read or Single Write. Set the timing chart values needed in relation with CLKOUT and GCLK1, and calculate the 32-bit RAM Array Words necessary to generate the pattern. (See the MPC860 User's Manual, Memory Controller section).

For our example, the RAM Array words calculated are 0x1FF77C35 and (0xEFCABC34, 0x1F357C35) for the initial precharge and the mode register set command.

As can be seen in any SDRAM specification sheet, it is programmed by issuing a Mode Register Set command. This is begun by the MPC8XX by using the Memory Controller's Memory Address Register (MAR) to toggle the address lines which we calculated above. And then we use the Memory Controller's Memory Command Register (MCR) to execute a run command of the RAM Array words above necessary for initialization. Note that we use two UPM RAM words to handle the MRS command to be able to set up the address via MAR in time. Then we execute the appropriate 8 refreshes which signals the end of the SDRAM's initialization sequence. Finally, we set the refresh rate to 4 for normal operation as described below and program the mode register. The choice to do a refresh burst of 4 beats at once is an arbitrary decision. Depending on your latency needs you may want to, e.g., do single beat refreshes and set up the refresh timer appropriately in the respective MxMR.

6.5 SDRAM Initialization

Following power-up, the initialization sequence as shown below should be executed. This description follows the steps in section 3.3 on page 7, but in much greater detail for this specific example.

- 1) UPMB should be programmed with values designating Single Read at offset 0x00, then program the initialization words above into offset 0x05, Burst Read at offset 0x08, Single Write at offset 0x18, Burst Write at offset 0x20, Refresh at offset 0x30, and Exception at offset 0x3C.
- 2) Program the Memory controller's MPTPR, MBMR, OR4 and BR4. We are using the starting address of 0x3000000 - 0x33FFFFFF.
- 3) Wait the SDRAM start-up delay time of 200 μ s before doing any SDRAM access.
- 4) Set the MAR to 0x88 for initialisation and the Mode Register Set.
- 5) Issue a precharge command for both banks using the pattern in location 0x05.
- 6) Set the MCR to 0x80808830 to run the refresh sequence (immediately runs 8 Refresh cycles).
- 7) Set the MCR to 0x80808106 to run the MRS command programmed in locations 0x06 and 0x07 of UPMB.
- 8) The SDRAM is refreshed using its auto-refresh mode. This is accomplished by using the UPM B's periodic timer. A burst of four auto-refresh commands is issued to the SDRAM every 62.4 μ s, so that all 2048 SDRAM rows are refreshed within specified 32.8 ms.
- 9) The SDRAM is initialized and ready for operation.

6.6 MPC8Bug Programming Example

The following example illustrates how to set up SDRAM patterns. Note that the patterns are based on updated UPM timings as outlined in section IV on page 14.

```
#####
# SDRAM - Fujitsu MB811171622A-100MHz Initialization Routine      #
# MPC8XX with bus speed of 50Mhz, using a 4Mhz oscillator.      #
# UPM B used as controller                                      #
#####
{
    # Single Read, 50 MHz (offset 0x00 in upm ram)
    upm :b 0, 1F07FC04 EEAFC04 11ADFC04 EFBBBC00 1FF77C47

    # Precharge and MRS, (using free space in UPMB)
    upm :b 5, 1FF77C35 EABC34 1B57C35

    # Burst Read 50MHz (offset 0x08 in upm ram)
    upm :b 8, 1F07FC04 EEAFC04 10ADFC04 F0AFC00 F0AFC00 F1AFC00 EFBBBC00 1FF77C47

    # Single Write, 50 MHz (offset 0x18 in upm ram)
    upm :b 18, 1F27FC04 EEAFC00 01B93C04 1FF77C47

    # Burst Write, 50 Mhz (offset 0x20 in upm ram)
    upm :b 20, 1F07FC04 EEAFC00 10AD7C00 F0AFC00 F0AFC00 E1BBBC04 1FF77C47

    # Refresh, 50 Mhz (offset 0x30 in upm ram)
    upm :b 30, 1FF5FC84 FFFFC04 FFFFC04 FFFFC04 FFFFC84 FFFFC07

    # exception (offset 0x3c in upm ram)
    upm :b 3c, 7FFFC07

    # MPTPR (divide by 16)
    rms memc mptpr 0400

    # machine B mode register SDRAM 32MHz brgclk
    rms memc mbmr 80802114 # (D0802114 for 50MHz)

    # option register 4 - SDRAM 4 MBytes,
    rms memc or4 FFC00A00

    # base register 4 - SDRAM @ 3000000 on upm B
    rms memc br4 030000C1

    # start SDRAM init: (note that required wait timings are not shown)
    rms memc mar 88 # MR 88 for high range
    rms memc mcr 80808105 # run precharge pattern from loc 5
    rms memc mcr 80808830 # run refresh pattern 8 times
    rms memc mcr 80808106 # run MRS pattern from loc 6
}
```

Part VII Revision History

REV 0.0: Original

REV 0.1: BS now driven by PQ_A8 in Figure. ROW address is made up by PQ_A(9:19) mapped to A(10:0) on the SDRAM, COLUMN address is made from PQ_A(20:29) mapped to A(9:0). Note that Physical connection is between PQ_A(20:29) to A(9:0), GPL0 to A10, but programmed to assert PQ_A(9).

REV 0.2: BS changed to PQ_A10 in Figure (corrected address multiplexing error).

REV 0.3: (HWG) major rework to include information about different bus speeds and UPM issues.

REV 0.4: (HWG) Clarified ambiguous wording about address usage and wait clocks. Some minor cosmetic corrections. Clarifications in section IV on page 14. Incorrect timing description in section 3.7 on page 11 fixed.

REV 0.5: (HWG) More text fixes. Added section about design variations. GPL line usage matches the reference designs now. Binary numbers marked with "0b".

REV 0.6: (HWG) Date change and revision bump for another release.

REV 0.7: (HWG) Added some technology comments and more explanations.

REV 0.8: (HWG) Added input from co-authors. Some edits for more current Micron SDRAM.

REV 0.8: (HWG) Major rework to integrate Janet Snyder's design example with code app note. Took PC SDRAM specification into account.

REV 0.9: (HWG) Date code fix according to the official timing sheet.

REV 1.0: (HWG) Fixed MRS command. Something got lost in the Cut & Paste phase, *sigh*. MRS needs to use two UPM RAM words or the addresses won't be set up in time. The previous single RAM word pattern most likely worked by accident only. The initial refresh should also be eight beats now. This had not been noticed before as the common setup times for ADS boards left enough room for normal refresh cycles to kick in. Also fought with the spell checker one last time.

REV 1.1: (HWG) Some more typos fixed. UM references now mention Rev 1. The cycle count statements were misleading. The rework lead to single beat writes for 40 MHz now being shown as slower than before to be in line with the rest of the description.

REV 1.2: (HWG) WIP. Revisited cycle counts again. Now the info should be fairly consistent. Hopefully.

REV 1.3: (HWG) Typo fixes and a note added to the cycle count table. Write timings can possibly be improved in real designs.

REV 1.4: (HWG) Initialization and MAR handling was not matching in section 6.4 and section 6.6.

REV 1.5: Revised for new documentation template and standards.

How to Reach Us:

Home Page:

www.freescale.com

E-mail:

support@freescale.com

USA/Europe or Locations Not Listed:

Freescale Semiconductor
 Technical Information Center, CH370
 1300 N. Alma School Road
 Chandler, Arizona 85224
 +1-800-521-6274 or +1-480-768-2130
support@freescale.com

Europe, Middle East, and Africa:

Freescale Halbleiter Deutschland GmbH
 Technical Information Center
 Schatzbogen 7
 81829 Muenchen, Germany
 +44 1296 380 456 (English)
 +46 8 52200080 (English)
 +49 89 92103 559 (German)
 +33 1 69 35 48 48 (French)
support@freescale.com

Japan:

Freescale Semiconductor Japan Ltd.
 Headquarters
 ARCO Tower 15F
 1-8-1, Shimo-Meguro, Meguro-ku,
 Tokyo 153-0064
 Japan
 0120 191014 or +81 3 5437 9125
support.japan@freescale.com

Asia/Pacific:

Freescale Semiconductor Hong Kong Ltd.
 Technical Information Center
 2 Dai King Street
 Tai Po Industrial Estate
 Tai Po, N.T., Hong Kong
 +800 2666 8080
support.asia@freescale.com

For Literature Requests Only:

Freescale Semiconductor Literature Distribution Center
 P.O. Box 5405
 Denver, Colorado 80217
 1-800-441-2447 or 303-675-2140
 Fax: 303-675-2150
LDCForFreescaleSemiconductor@hibbertgroup.com

Information in this document is provided solely to enable system and software implementers to use Freescale Semiconductor products. There are no express or implied copyright licenses granted hereunder to design or fabricate any integrated circuits or integrated circuits based on the information in this document. Freescale Semiconductor reserves the right to make changes without further notice to any products herein. Freescale Semiconductor makes no warranty, representation or guarantee regarding the suitability of its products for any particular purpose, nor does Freescale Semiconductor assume any liability arising out of the application or use of any product or circuit, and specifically disclaims any and all liability, including without limitation consequential or incidental damages. "Typical" parameters which may be provided in Freescale Semiconductor data sheets and/or specifications can and do vary in different applications and actual performance may vary over time. All operating parameters, including "Typicals" must be validated for each customer application by customer's technical experts. Freescale Semiconductor does not convey any license under its patent rights nor the rights of others. Freescale Semiconductor products are not designed, intended, or authorized for use as components in systems intended for surgical implant into the body, or other applications intended to support or sustain life, or for any other application in which the failure of the Freescale Semiconductor product could create a situation where personal injury or death may occur. Should Buyer purchase or use Freescale Semiconductor products for any such unintended or unauthorized application, Buyer shall indemnify and hold Freescale Semiconductor and its officers, employees, subsidiaries, affiliates, and distributors harmless against all claims, costs, damages, and expenses, and reasonable attorney fees arising out of, directly or indirectly, any claim of personal injury or death associated with such unintended or unauthorized use, even if such claim alleges that Freescale Semiconductor was negligent regarding the design or manufacture of the part.

